

Phone Connections for Home Users

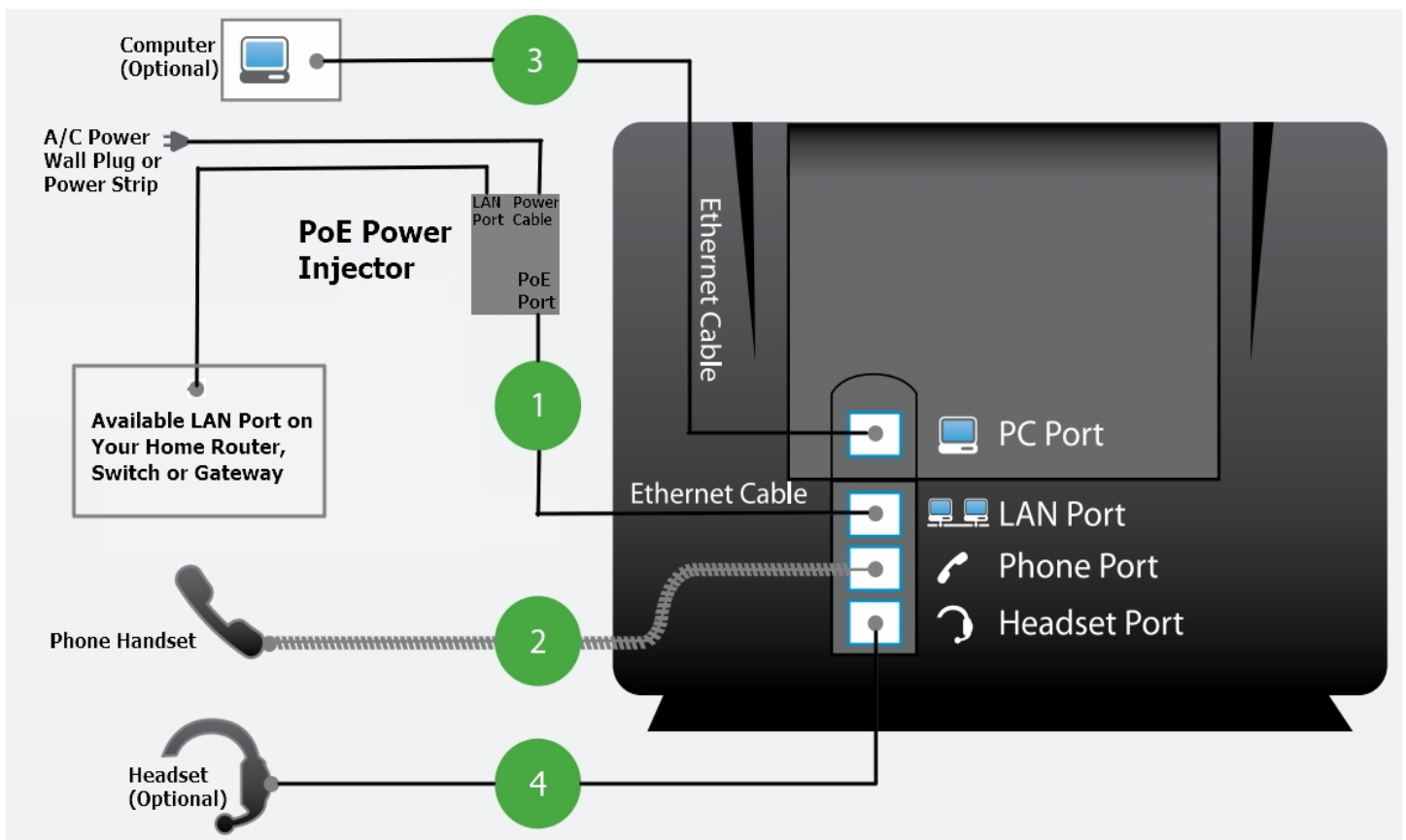

- 1a.** Plug in an Ethernet Cable from the PoE Port on the PoE Injector to the LAN Port on the phone.
- 1b.** Plug in an Ethernet Cable from the LAN Port on the PoE Injector to an available LAN Port on your Router, Switch or Gateway.
- 1c.** Plug in the Power Cable from the PoE Injector to a wall plug or power strip.
- 2.** Plug in the curly handset cord from the Handset “Phone Port” on the phone to the Phone Handset.
- 3.** Optional: The PC Port can be used to connect a computer to your home network.
- 4.** Optional: Professional headsets. Use the User Web Portal to program a “Headset” Key.

Connecting the Phone Stand

5. Hinge the hooks of the base unit into the notches on the back of the phone and snap into place as follows:
 - a. For a high-angle mount, hinge the two lower hooks into the bottom set of notches and snap the two upper hooks into the middle set of notches.
 - b. For a low-angle mount, hinge the two lower hooks into the middle set of notches and snap the two upper hooks into the top set of notches.

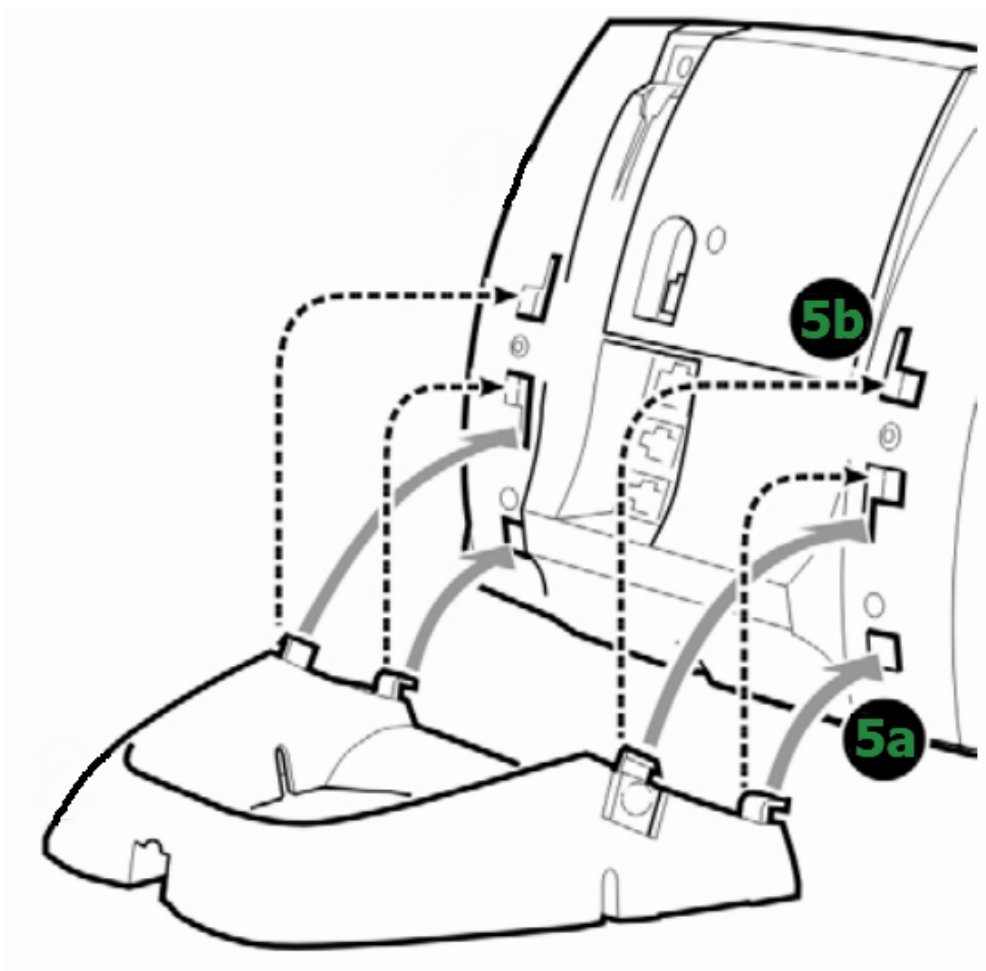



UniVoIP IP Phone Quick Start Guide

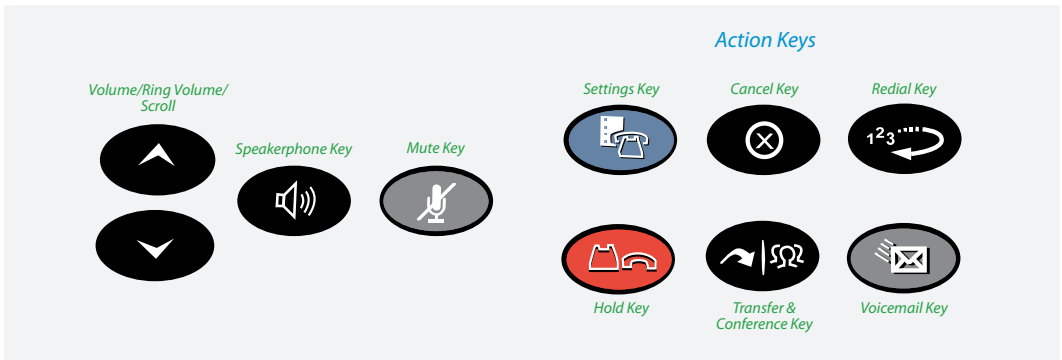

Quick Start Guide - Using Your Phone

LOGGING INTO A PHONE

Press the *Hot Desk* soft key. Press the *Login* soft key. Enter your extension number and press the OK soft key. Enter your phone PIN number and press the OK soft key. Your PIN is in your Welcome Email. It may be the same as your extension number.

MAKING CALLS

External Calls

To make an external call, dial 9 + the number (area code first).

Internal Calls

Internal calls can be made by just entering the extension number of your colleague.

International Calls

To make calls outside of the United States, dial 9 + 011 + Country Code + City Code + the phone number of the person you are trying to reach.

RECORDING VOICEMAIL GREETING

To record or change your voicemail greeting. Press the *Voicemail* button  on your phone and enter your VM passcode, then follow the prompts to record your greeting.

LISTENING TO VOICEMAIL MESSAGES

From Your Desk Phone

Press the  key and follow the prompts.

From Any Phone Outside Your Office

1. Call your own phone number
2. During your voicemail greeting press the * (star) key and follow the prompts.

REDIAL

Press the  function key to call the last number you have previously dialed.

PLACING A CALL ON HOLD

When you are on a call and need to place someone on hold, press the red hold key .

This places the call on hold. Take the call off hold by pressing the flashing *Line Appearance* key.

TRANSFERRING A CALL

Once on an active call, you can transfer a call by pressing the Transfer action key . The call will be on hold. Dial the internal or external number. Announce the call or not, then simply hang up or press the **Release Me** Soft Key. The call will then be transferred to the other party.

MAKING A THREE-WAY CALL OR CONFERENCE CALL



Dial the first party's number, then press the *Transfer* action key . The call will be on hold. Dial the next party and press the Transfer action key. You now have a 3-way call. To add more parties to the call, **Transfer** | Dial | Transfer. An 8-way call is the maximum.

Quick Start Guide – Using Your Phone



ADJUSTING YOUR PHONE DISPLAY SETTINGS

You can adjust and personalize your phone's settings by clicking on the blue action key . Here you will see a list of the display features: Text Size, Brightness and Contrast, Screen Saver and more. To view or adjust any of these settings, simply click on the button next to the appropriate category.



ADJUSTING THE SPEAKER VOLUME

Press   to adjust the volume of the handset, headset and speakerphone during a call.

ADJUSTING THE RINGER VOLUME

Press   when the phone is ringing.

MUTING A CALL

Press  to mute the microphone during a call. Then press  to turn off mute.

NOTE: This command works whether you are using the headset, handset or speakerphone. When on a call, if your phone is muted and you need to enter command keys, unmute the microphone to ensure that they transmit properly.

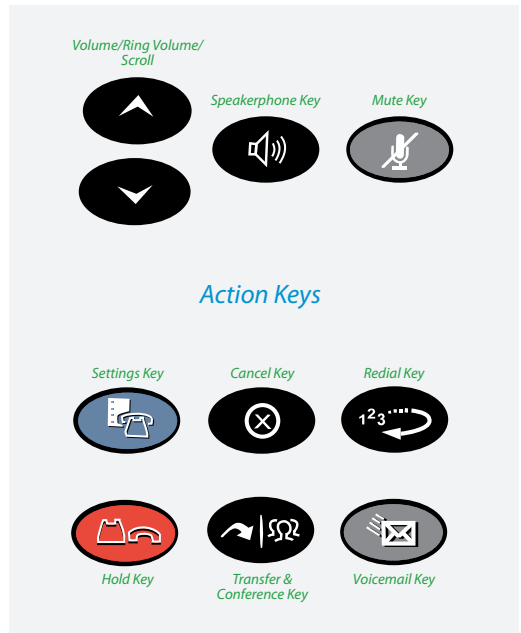

UniVoIP Support

A “Support” speed dial key has been programmed on your phone. Press this key to reach UniVoIP Support, or you can call 877-660-6677. Regular support hours are M-F, 9am to 5pm PST.

Short “Getting Started” videos are ready for viewing...your administrator can email you the link to the playlist.